

Team 07: Light the [K]Night

Kai Barboza, Matthew Carlson, Thomas Noble, Alayna Spiering, Andrew VanderPloeg, Calvin University, Grand Rapids, Michigan

Introduction

Driving at night is inevitable which means the need for lamp posts will never go away. Lamp posts are seen on most roads, but their presence are less frequent on roads that are further away from a grid due to their innate costs. With advancements in wind energy, in leagues with solar and natural gas, lampposts can be fully and eco consciously by a wind turbine.

Objectives

Some of the objectives that Team 07 developed for this project are as follows:

- Sustainable
- Cost efficient
- Battery system can charge and discharge.
- Obtains energy from wind at over 25% efficiency.
- Clamping structured must be able to support up to 300 lbs.
- Have less than 30% energy loss from the turbine to the batteries.

Design

Blades

Through using the program Q-Blade, it allowed for the blades to be designed based on the climate within Grand Rapids, Michigan.

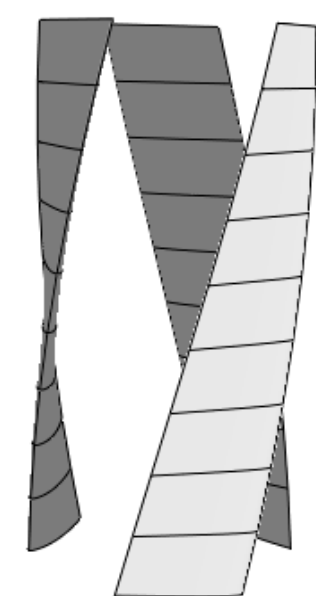

Figure 1: Blade Design from Q-Blade

Electrical

By understanding the necessary process of electricity that will be produced by the vertical axis wind turbine. Through using the proper equipment shown in Figure 2, it allowed for the batteries to be charged and discharged to light the lamp post.

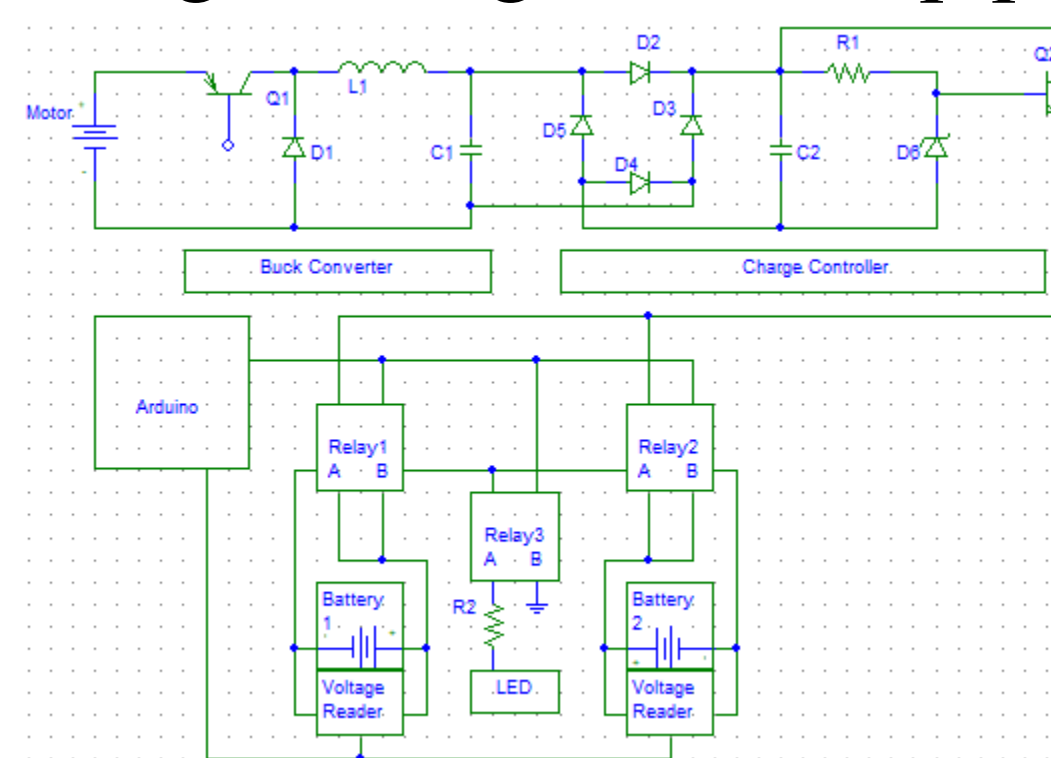

Figure 3: Electrical System Schematic

Support System

To determine the correct system design to support the weight of the blades and the electrical components through FEA, it allowed for the the proper material and design to be chosen. With three main aspects: harness, a-frames, and shafts.

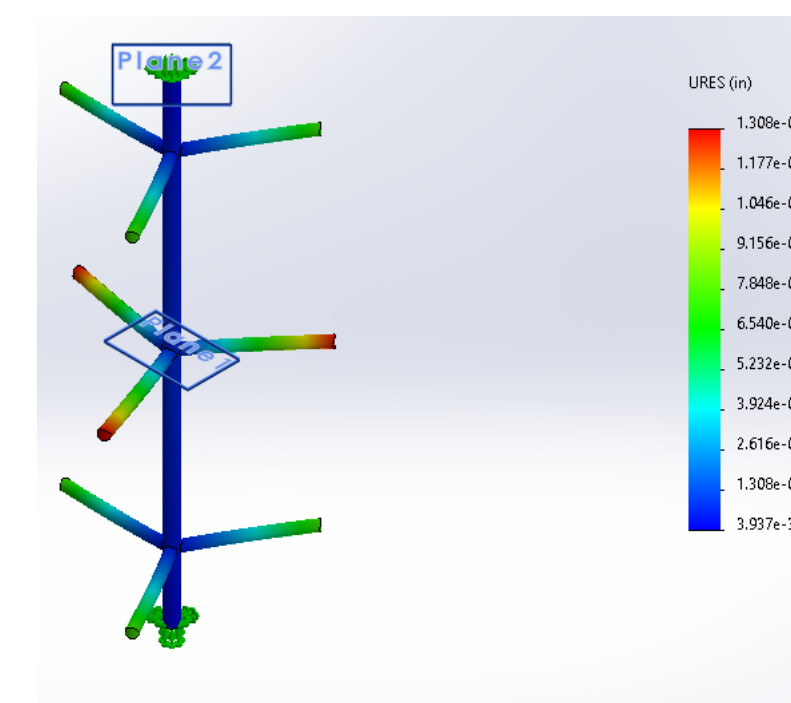

Figure 3: Blade Shaft FEA

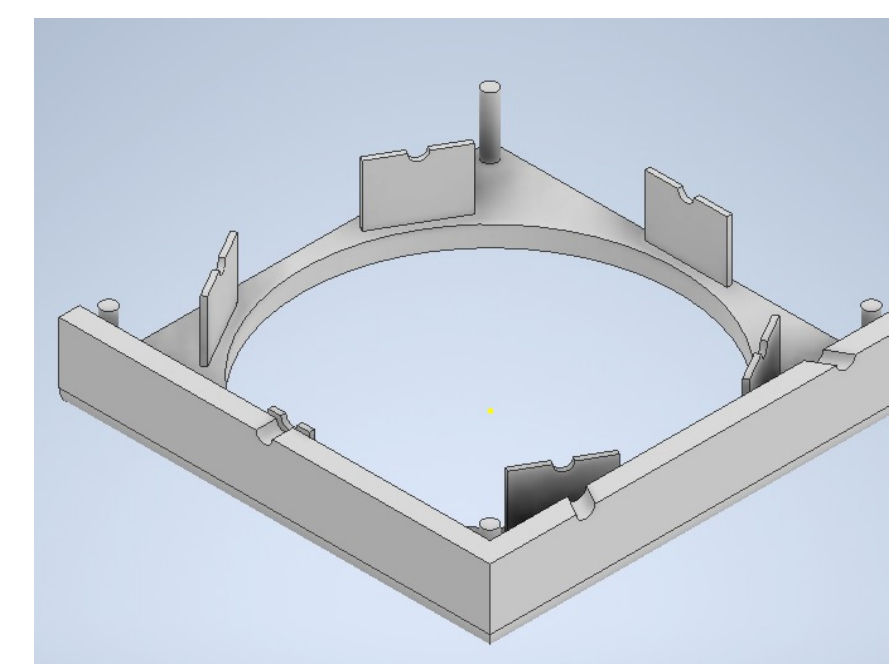
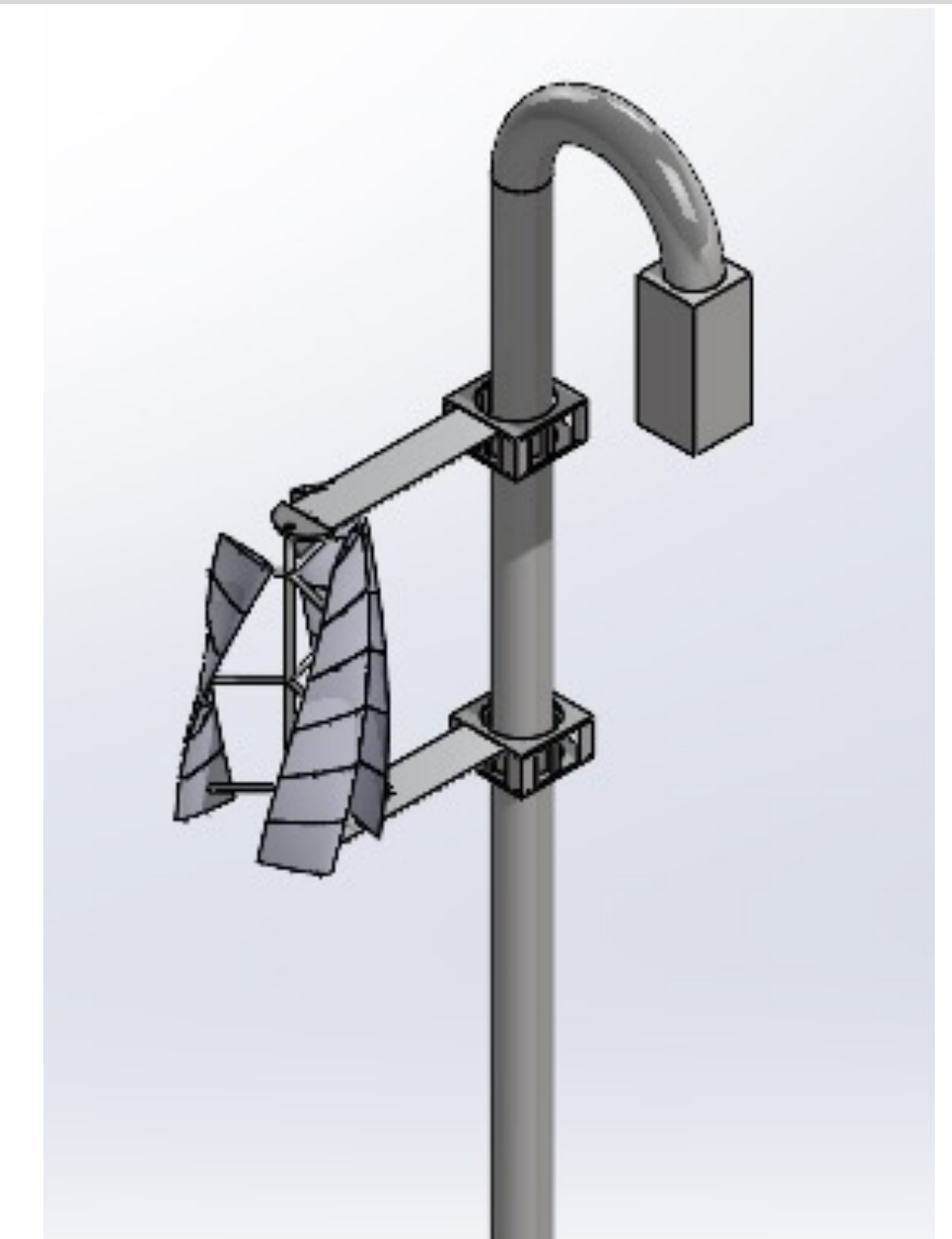

Figure 4: Cross Sectional View of Harness

Improvements

- Lithium batteries so that the battery system could last longer.
- Bigger blades to get more torque from the wind.
- Higher gear ratio to provide the correct amount of RPMs
- Develop a more decisive method in the creation of the a-frame.



Final CAD design of the Vertical Axis Wind Turbine Excluding the Blades.

Conclusions

Through developing and designing a vertical axis wind turbine, it created a new option for ways to power lamp posts. By using this vertical axis wind turbine, it would create a sustainable option in producing electricity along with developing an efficient wind turbine in energy production.

Acknowledgements

- Eric DeGroot
- Professor Tubergen
- Professor Hartemink
- Professor Haan
- Jeff DeHeer